

Hoffman|Controls

Product Data

880-25 Low Ambient Head Pressure Control for ECM Motors

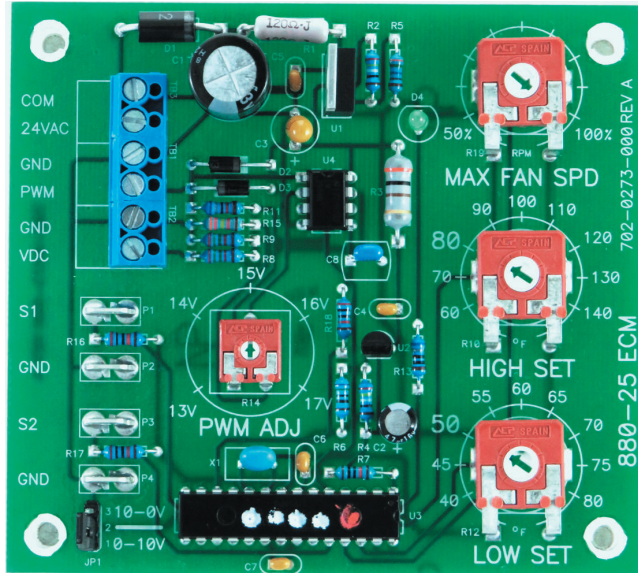

10K TEMPERATURE SENSOR INCLUDED

Description

The 880-25 Low Ambient Head Pressure Control is designed to modulate energy efficient Electrically Commutated condenser fan Motors (ECM) in air conditioning and refrigeration systems. The 880-25 control varies the speed of the condenser fan ECM motor(s) to vary the air volume through the condenser consequently regulating head pressure for proper heat rejection in low ambient temperatures.

The 880-25 Head Pressure Control monitors the head pressure by sensing the sub-cooled liquid line temperature by placing a 10K sensor on the refrigerant liquid line. As the liquid line temperature drops, the motor speed will be reduced to prevent freezing of the coil. As minimum motor speed is reached, the control will cycle the motor off until the liquid line coil temperature has returned to safe operating levels. At this point, the motor will modulate back to full speed to maintain proper heat rejection. The 880-25 control provides an adjustable LOW SET point of 40°F to 80°F and an adjustable HIGH SET point of 60°F to 140°F for the ability to custom tune the control for any application.

The 880-25 Head Pressure Control also provides a Maximum Fan Speed adjustment of 50% to 100% for fine tuning the condenser fan CFM rate.

Description Con't

The common settings for most applications is a LOW SET point of 50°F and a HIGH SET point of 80°F. In this example, the condenser fan(s) modulate from full speed which occurs at 80°F liquid line (ambients above 60°F), and reaches minimum speed at 50°F liquid line temperature (ambients below 30°F). The ECM condenser fan motor(s) cycles "OFF" at liquid line temperatures below 50°F, and cycles back "ON" to minimum speed at 53°F liquid line temperature. The ECM condenser fan motor will modulate from minimum speed to full speed between 53°F and 80°F.

The 880-25 control includes two liquid line sensor monitoring inputs with the hottest sensor controlling operation, sensor temperature Low & High set point and maximum fan speed adjustments, with LED set point indicator, Self-Test mode, Hard Start feature and a 20ma (typically two) ECM motor drive capability. The 880-25 control provides three ECM motor drive options: a jumper selectable 0-10VDC or 10-0VDC (fail safe) signal and/or an adjustable 13-17VDC, 80Hz PWM signal.

880-25 Features and Specifications

- Not refrigerant specific Class II Controller, conformal coated.
- One or up to two liquid line temperature sensor inputs with the hottest sensor controlling operation.
- Removing sensors from the sensor inputs will Self-Test ECM motor full speed operation.
- Temperature input Low Set Point range 40°F to 80°F and High Set Point range 60°F to 140°F in 1°F increments.
- ECM motor drive options include an adjustable 13-17VDC peak/80Hz PWM signal, selectable 0-10VDC or 10-0VDC (fail safe) signals.
- 20ma ECM motor drive capability (typically two motors).
- 2.5 second full speed Hard Start.
- 50% to 100% maximum Fan Speed adjustment.
- Operating Ambient -31°F to +160°F, Humidity 95%, Non-condensing, Dimensions 3.5L x 4.0W x 1.5H, Power supply 22-30VAC, 1VA.

880-25 WIRING DIAGRAM

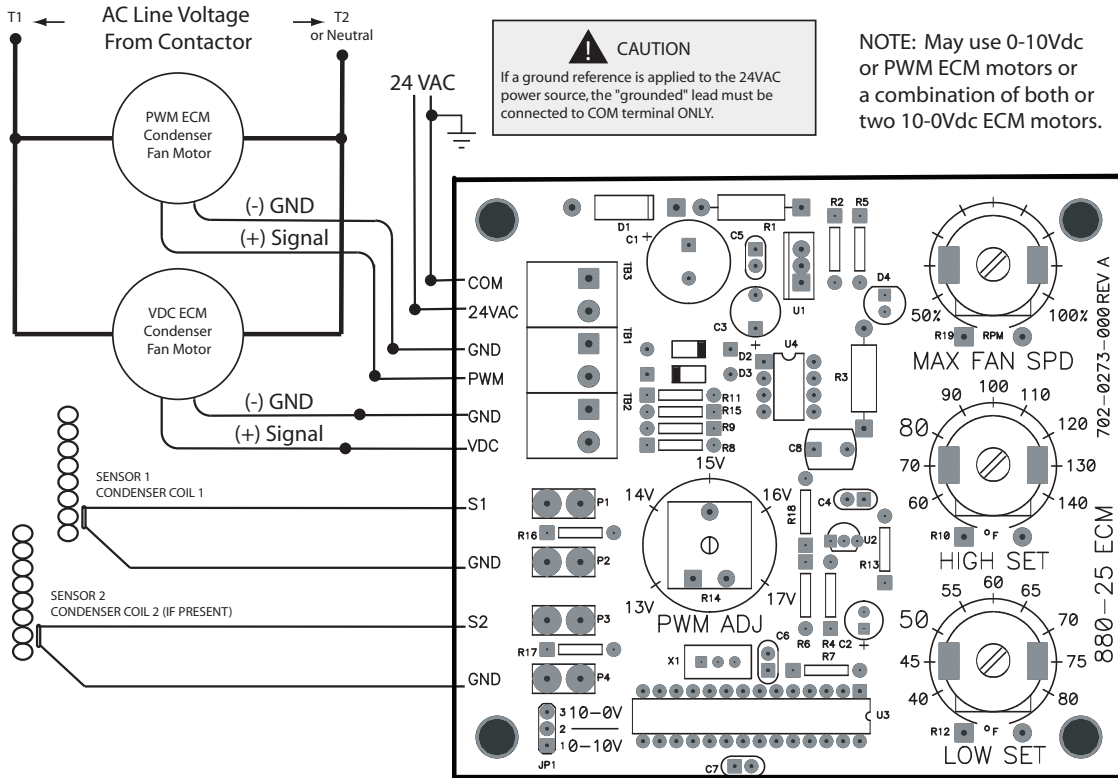

Low Ambient, Condensing, Sub Cooling, and Liquid Line Values for Constant, Variable, and Fan Cycling Operations

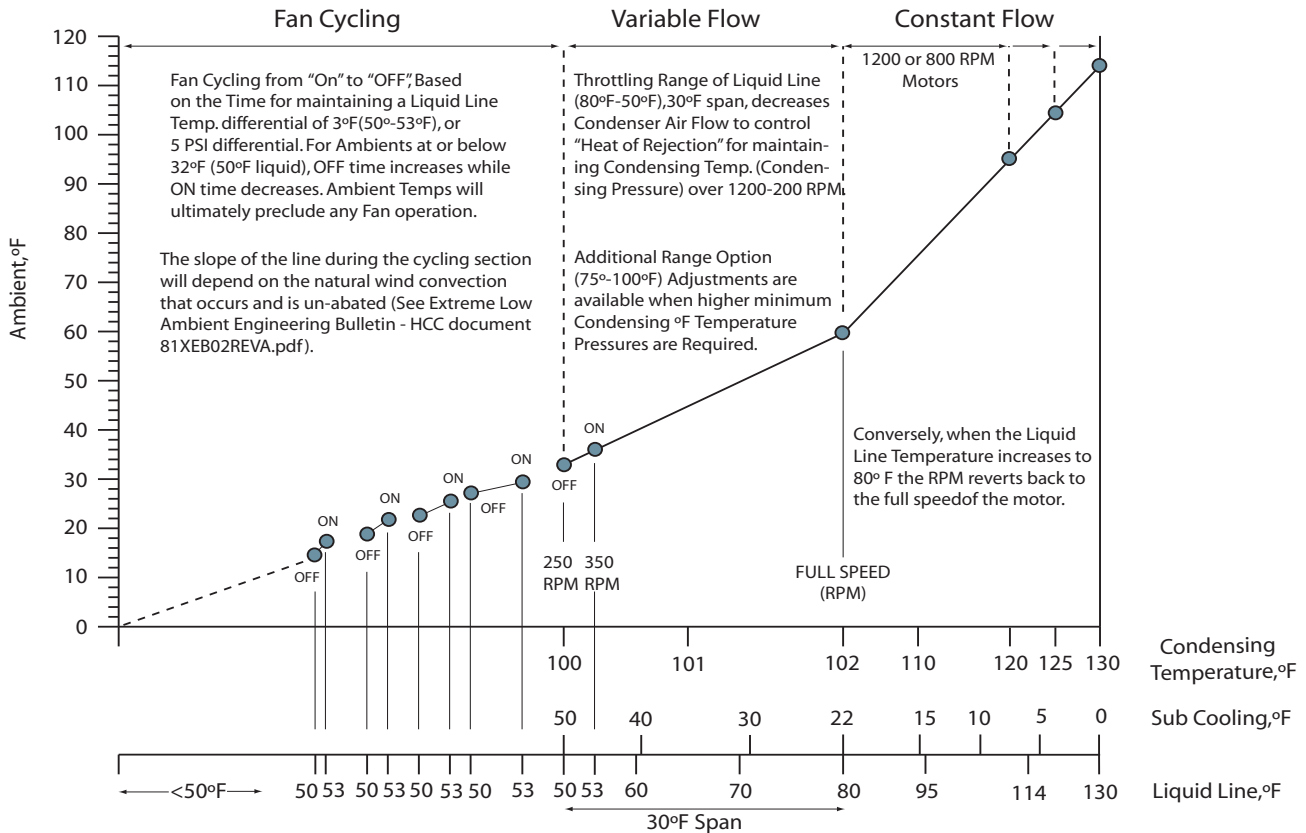

Typical Fan Operation with Ambient, Condensing, and Liquid Line Temperatures

Hoffman|Controls