

Hoffman Controls

Installation & Operating Instructions

880-20 Low Ambient Head Pressure Control for ECM Motors

General

CAUTION

Failure to read and understand the accompanying instructions and diagrams or failure to complete the "Checkout Procedure" prior to energizing the Control may result in permanent damage to the Control.

The 880-20 Low Ambient Head Pressure Control is designed to modulate energy efficient Electrically Commutated condenser fan Motors (ECM) in air conditioning and refrigeration systems.

The control monitors the head pressure by sensing the sub-cooled liquid line temperature and varies the air volume through the condenser consequently regulating head pressure for proper heat rejection in low ambient conditions.

Pre-Installation

1. For use with ECM condenser fan motors capable of accepting a 0-10Vdc, 10-0Vdc (fail safe signal) or 13-17Vdc amplitude, 80Hz Pulse Width Modulated (PWM) control signal.
2. The control provides 20mA (typically two ECM motors) of motor drive capability and works with all motor line voltages.
3. The control can monitor one or two refrigerant circuits with 10K liquid line temperature sensors. When using two sensors, the hottest sensor is in control. The 880-20 is supplied with one sensor. Additional sensors p/n 100-0016-001 may be purchased.
4. The control requires an external 24Vac, 1VA power source.
5. Wiring must comply with Local and National Electrical Codes.
6. Refer to 880-20 Product Data (HCC #172-0268-000) to insure a complete understanding of the controllers function before continuing installation.

Installation

WARNING

Disconnect power from the unit and electrically disable the compressor prior to installation.

- Install the 880-20 control in a weatherproof control panel or use a NEMA Series type 2, 3, or 3R enclosure. The control is conformally coated but must be protected from moisture and condensation.

- Determine an appropriate mounting location and attach the control using four sheet metal screws through the circuit board four corner standoffs.
- Dimensions and mounting hole patterns for the control are included in Figure 2, 880-20 Mounting Template.
- Make the wiring connections as shown in Figure 3, 880-20 Wiring Diagram.
- Note: Attach the ECM motor speed control signal to the PWM(+) & GND(-) terminals for PWM type motors and attach the 0-10Vdc or 10-0Vdc type motors to the VDC(+) & GND(-) terminals. It is acceptable to use both PWM and VDC type motors at the same time.
- The 24Vac "COM" terminal allows for grounded 24Vac supply if required.

Liquid Line Sensor

- Install the supplied 10K Sensor to the top of liquid line where the line exits the condenser coil as shown in Figure 1, Sensor Installation.

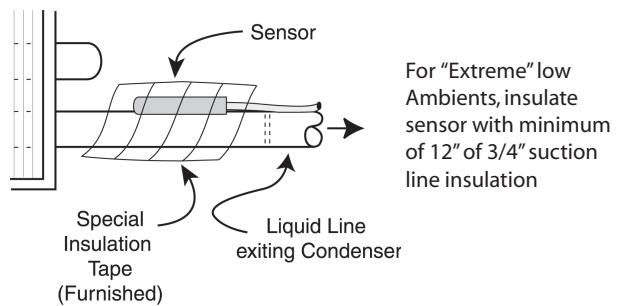

Figure 1 - Sensor Installation

- Use the special tape provided to secure the Sensor to the liquid line. Stretch the tape slightly, as you wrap Sensor around the liquid line. Use all the tape, lapping the Sensor. Firm contact is required between the metal tab of the Sensor and the liquid line.
- Connect the 1st sensor to the control's input terminals S1 & GND (minimum of 1 sensor required). Note that it doesn't matter which of the two sensor wires is attached to GND.
- If monitoring two refrigerant circuits, install the 2nd sensor to the 2nd condenser coil as shown above and connect it to the controls' input terminals S2 & GND.
- Additional insulation of the taped sensor and adjacent refrigerant line back to condenser header may be required in extremely cold ambients (+20°F).
- Refrigeration applications or extremely low ambient environments may require additional consideration. Consult factory or see Engineering Bulletin (HCC #81XEBO2REVA) for "Low Ambient Considerations".

PWM ADJ Potentiometer

It may be necessary to adjust the PWM ADJ potentiometer when using an ECM condenser fan motor(s) that uses a PWM type motor speed control signal. It will be necessary for the installer to have the motor manufacturers' specifications for the amplitude of the PWM signal.

Example: If the manufacturers' PWM amplitude specification is 9-15Vdc, set the PWM ADJ potentiometer below 15Vdc. If the manufacturers' PWM amplitude specification is 15-30Vdc, set the PWM ADJ potentiometer above 15Vdc.

The PWM ADJ potentiometer is set at 15Vdc from the factory and this setting will work with most PWM type ECM condenser fan motors.

LOW & HIGH SET Potentiometers

The LOW SET point and HIGH SET point adjustments are critical settings for proper heat rejection in low ambient conditions. The 880-20 control maintains the pressure differential at the expansion valve for proper superheat.

The LOW SET point has a range of 40°F to 80°F in 1°F increments. The HIGH SET point has a range of 60°F to 140°F in 1°F increments. This wide range of adjustment provides head pressure control for typical and unique applications. Should the HIGH SET point be set below the LOW SET point, the control assumes the HIGH SET point value is the LOW SET point plus 3°F.

The **factory setting** is 50°F (LOW SET) and 80°F(HIGH SET) providing a 30°F range (span) of ECM condenser fan motor modulation for the typical Thermal Expansion Valves (TXV) type systems. In this example the condenser fan motor(s) modulation from full motor speed occurs at 80°F liquid line (ambients above 60°F) and modulates motor(s) to minimum speed at 50°F liquid line (ambients below 30°F). The motor(s)cycles "OFF" at liquid line temperatures below 50°F and cycles back "ON" first with a 2.5 second full speed hard start then to minimum speed at 53°F liquid line temperature providing 3°F of hysteresis between motor "OFF" and "ON".

A 25°F span (settings of 55°F to 80°F) is recommended for High Efficiency systems. Settings of 70°F to 100°F are recommended for Capillary Tube or Orifice type systems.

CAUTION: These various set point adjustments are provided only to ensure proper ambient control when the system is properly charged (no vapor in the sight glass), filters, condenser and evaporator coils are clean, and the system is properly charged.

LED Set Point Indicator

When either of the LOW or HIGH set point potentiometers is turned, the LED will flash the new reading. A sequence of flashes indicates a digit from 1-9. A "zero" is indicated by a low-brightness pulse. For example, if the set point is 105°F, the LED will flash once, then pause, then display a dim glow, then pause, then flash five times. The LED set point indicator provides the installer with the assurance that the set points have been entered exactly as desired.

During normal operation the LED intensity will increase with the fan motor(s) speed.

ECM Motor Selection

When using an ECM condenser fan motor(s) that accepts a 0-10Vdc or 10-0Vdc (fail safe mode) speed control signal, move the JP1 jumper tab to the appropriate location as shown below.

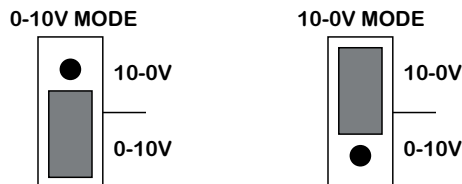

The 880-20 control PWM and 0-10Vdc motor maximum speed output is 97% duty cycle PWM and 9.7Vdc. The minimum speed output is 20% duty cycle PWM and 2.0Vdc. Motor off is 0% duty cycle PWM and 0.0Vdc. If using 10-0Vdc mode, the motor maximum speed output is 0.0Vdc and the minimum speed output is 8.0Vdc. Motor off is 9.7Vdc.

Checkout Procedure

CAUTION



Verify all ECM motor connections & configuration before applying power.

1. Verify line voltage is correctly applied to the motor terminals.
2. Verify motor has been programmed for correct rotation (CW/CCW) and is selected for the recommended propeller blade.

Prepare for Operation

1. It is recommended that the compressor be disabled prior to control and condenser fan motor(s) operation checkout.
2. Disconnect one lead of the first temperature sensor and one lead of the second sensor (if used) from the control. The control LED will flash continuously and the motor(s) will run at full speed if all wiring is correct.
3. Motor speed control can be tested by shorting either S1 or S2 sensor input to GND. The motor(s) speed will ramp up and down over a period of 15 seconds.
4. Once the control and motor wiring is verified, reconnect the sensor leads and the compressor power may be restored.
5. Set thermostat for cooling demand and apply voltage to the unit. Condenser fan will hard start if the liquid line is 3°F above the LOW SET point value and modulate over the span of the range selected.
6. Verify that the motor is operating properly for temperature sensed. Depending on the LOW & HIGH set points, when the sensor temperature at "start up" is:
 - a. **Below Selected Range**, the motor(s) will not start.
 - b. **Within Selected Range**, the motor(s) will first hard start and then modulate to a reduced speed proportional to the temperature sensed.
 - c. **Above Selected Range**, the motor(s) will start and remain at full speed.
7. Verify operation as described above by monitoring liquid line temperature and observing motor speed.

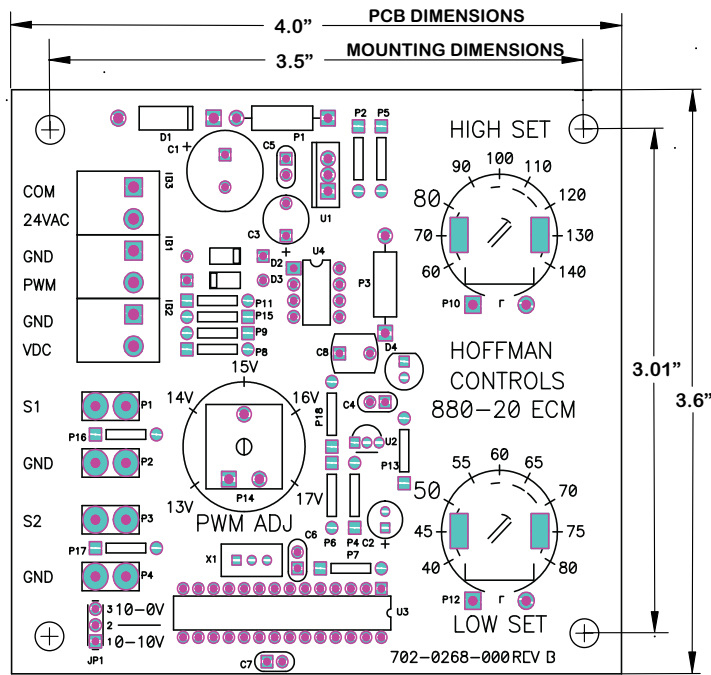

Figure 2 - 880-20 Mounting Templates (not to scale)

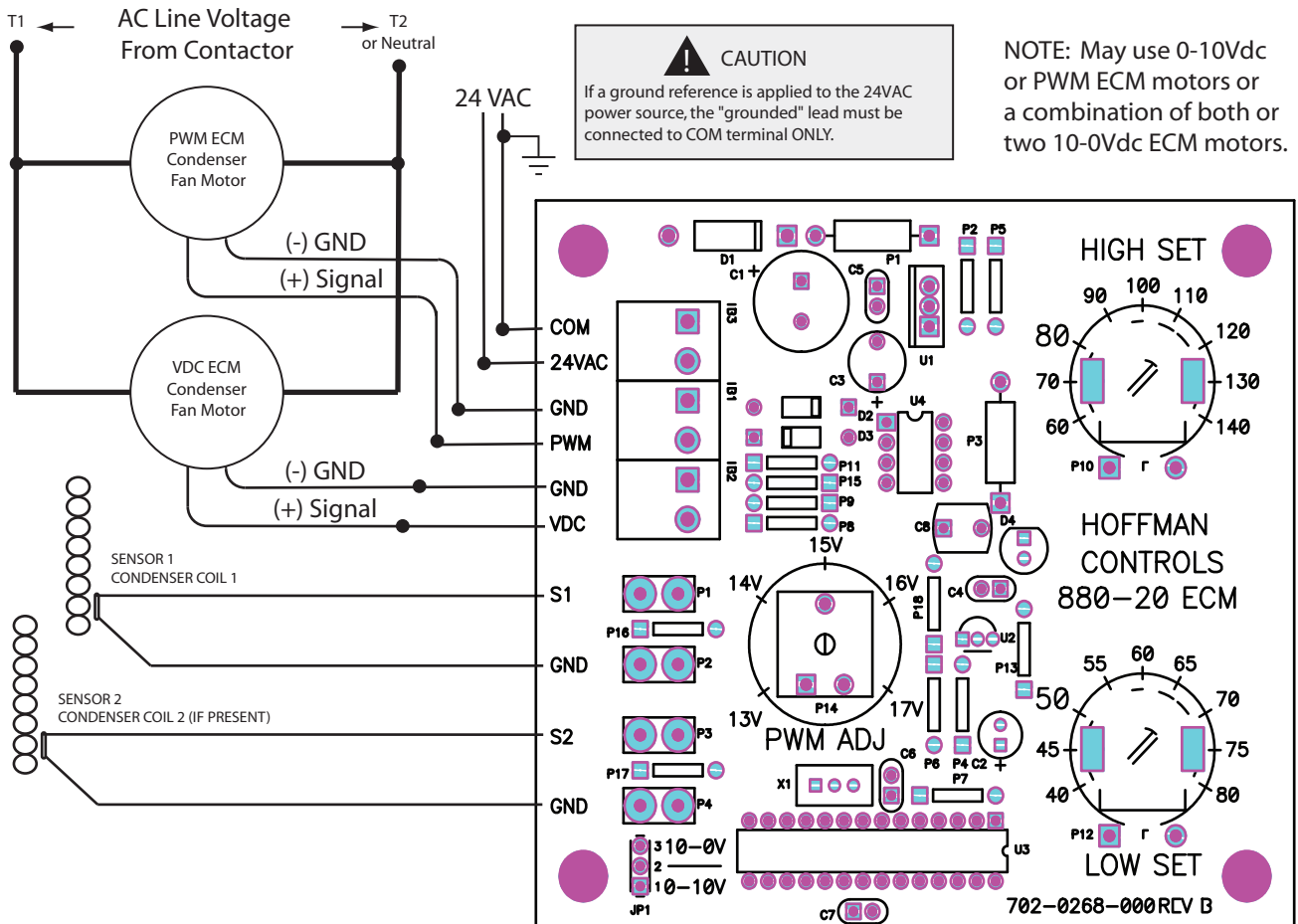

Figure 3 - Wiring Diagram for the 880-20 Control

Troubleshooting Guide

Condition	Cause	Solution
Motor Will Not Run	<ol style="list-style-type: none"> 1. Improper installation, Motor not wired correctly. 2. 24 VAC not present. 3. Sensor temperature below LOW SET point. 4. Motor "OFF" on internal overload. 5. 10-0Vdc Mode is selected when using a 0-10Vdc ECM condensor fan motor. 	<ol style="list-style-type: none"> 1. Check wiring, review instructions. 2. Verify 24 VAC supply. 3. Normal operation. 4. Motor protected. 5. Move JP1 jumper tab to the 0-10Vdc Mode.
Motor Runs at Full Speed Only	<ol style="list-style-type: none"> 1. Sensor open and LED flashing. 2. Control damaged. 3. Low refrigerant. (Hot gas in liquid line.) 4. Sensor temperature above HIGH SET point. 	<ol style="list-style-type: none"> 1. Replace Sensor. 2. Replace control. 3. Charge system. 4. Normal operation.
Motor Will Not Modulate Properly	<ol style="list-style-type: none"> 1. Sensor not properly located or attached to liquid line. 2. Sensor Ohms vs. Temperature measured not in compliance with values in Table 2. 3. System not properly charged. 4. Expansion valve is not properly metering refrigerant; cap tube or orifice not properly sized for low ambient operation. 5. Low evaporator temperature and /or head pressure. 	<ol style="list-style-type: none"> 1. Relocate per instructions. 2. Replace Sensor. 3. Recharge system. Add or remove refrigerant. (Liquid line must not indicate vapor/gas.) 4. Adjust or replace expansion valve, cap tube or orifice to provide proper control of lowside. 5. Reset LOW & HIGH SET points to assure evaporator temperatures above 32°F.

**System Troubleshooting Guide
Table 1**

Temp °F	Sensor (Ohms)	Temp °F	Sensor (Ohms)	Temp °F	Sensor (Ohms)
28.0	36,627	56.0	16,990	84.0	8,433
30.0	34,582	58.0	16,128	86.0	8,056
32.0	32,660	60.0	15,315	88.0	7,685
34.0	30,869	62.0	14,547	90.0	7,332
36.0	29,180	64.0	13,823	92.0	6,997
38.0	27,600	66.0	13,139	94.0	6,679
40.0	26,109	68.0	12,492	96.0	6,378
42.0	24,712	70.0	11,881	98.0	6,092
44.0	23,398	72.0	11,3033	100.0	5,820
46.0	22,160	74.0	10,8509	102.0	5,561
48.0	20,996	76.0	10,2095	104.0	5,316
50.0	19,899	78.0	9,750	106.0	5,094
52.0	18,872	80.0	9,287	108.0	4,873
54.0	17,903	82.0	8,848	110.0	4,662

**Temperature to Resistance Table - Key Point Values
Table 2**