

Microprocessor

Step Controller/Sequencer



904-S or 745-S

The 745 and 904 Microprocessor Controllers are identical in every respect except for one feature. The 904 Series Sequencer includes a Pulse Width Output; the 745 Step Controller does not provide this Pulse Width Output. All other Functions, Features and Accessories are identical, and provided for in either controller. The Pulse Output is made available on the 904 Series Controller to allow Solid State Relay(s) to directly receive the modulated pulse signal without any additional interfacing. When the Modulating Function is integrally used with Incremental Sequencing Stages, this function is referred to as a Vernier System.

Either model can be used as either a Direct Acting (Cooling) or Reverse Acting (Heating) function.

A controller however, is dedicated to one mode, and cannot have both heating and cooling functions within that same controller. When both Direct and Reverse Acting functions are utilized in the same system, two controllers are required. One or both modes can be disabled as may be required by closure of the Disable to Ground Terminal.

Both series have been designed to insure the most cost effective method for controlling incremental sequencing of stages. Either model can be provided with 4 or 6 stages of control integral to the main controller. Two (2) or four (4) stage Plug-in Boards can be added in increments of 2 steps, up to 14 stages total. This design/feature precludes the necessity of adding an additional Controller when more than Six Stages are required.

The Input Section

This series input section includes industry standard 2-10V DC, 4-20mA, and 135 ohm, analog inputs. When 135 ohm is required an Accessory plug-in card is necessary. An optional "Plug-In" On Board Set Point with a remote sensing probe is available for directly sensing temperature for a dedicated Heating or Cooling application. This OBS Series is made available in 50-90F and 30-180F ranges. (See 904/745-OBS Series Product Data for Details)

Sequencing Methods

Four methods of staging are provided; LIFO, FIFO, Binary A, and Binary B. LIFO is the more typical Method of Sequencing Stages. FIFO is sometimes called a "carousel" method which provides an average of equal ware for each of the stages. In addition to LIFO & FIFO, a Binary function providing significantly more stages, but requiring fewer relays is an economical as well as preferred method of control. LED indicators identifying energized stages, as well as the modulating stage(s), are furnished for all Sequencing Methods.

In the two following Tables, two functional descriptions depict two Binary Progressions which are embedded in Firmware in the controllers microprocessor.

Binary A is a progression of units of 1, 2, & 4, which will provide seven (7) equal steps utilizing only three stages (three relays). In most applications Binary A is more applicable for Heating Staging, where each stage can be manufactured to size. Using four relay stages, a Binary A progression of 1, 2, 4, & 8, providing fifteen equal incremental steps, can be obtained. Binary B is more applicable for Cooling Staging where compressors are being controlled and compressor capacity may not be available for the standard binary progression noted above. Binary B is a progression of 1, 1 1/2, and 2. This progression provides a first and last incremental stage of approximately 22%, and the second through sixth stage of approximately 11%. Thus furnishing 2 equal, and 5 equal steps, for a total of 7 steps.

Table A
Binary A Sequencing/Step Controller
Compressors and/or Electric Heating
Applications

Qty.	Load	BTU/T.R.	Load Ratio
1	A	1	Load 1/7 of total
1	B	2	Load 2/7 of total
1	C	4	Load 4/7 of total
3			

Table B
Modified Binary B Sequencing/Step Controller
Compressors and/or Electric Heating
Applications

Qty.	Load	BTU/T.R.	Load Ratio
1	A	1	Load 1/5 of total
1	B	1½	Load 1/3 of total
1	C	2	Load 7/16 of total
3			

Step or Sequencing Function

Load	Fraction	% of Total Load	Time Delay	
			3 ½ min	2 sec.
A only	1/7	14.29%	X	X
B only	2/7	28.57%	X	X
A & B only	3/7	42.86%	X	X
C only	4/7	57.14%	X	X
A & C only	5/7	71.43%	X	X
B & C only	6/7	85.71%	X	X
A, B, & C	7/7	100.0%	X	X

Step or Sequencing Function

Load	Fraction	% of Total Load	Time Delay	
			3 ½ min	2 sec.
A only	≈1/5	22.2%	X	X
B only	1/3	33.3%	X	X
C only	≈7/16	43.5%	X	X
A & B only	≈9/16	55.5%	X	X
A & C only	2/3	66.6%	X	X
B & C only	≈13/16	77.7%	X	X
A, B, & C	16/16	100.0%	X	X

Function – provides 7 equal steps with the management of 3 loads.

Function – provides 2 equal and 5 equal steps with the management of 3 loads.

- | | | |
|-----------|----|--|
| Start up | 1) | Immediately selects (provides) combination of A, B, & C to match error signal in span. |
| Shut down | 2) | Instantly shuts down all combinations of A, B, & C if signal is removed. |
| | 3) | Always provides either 3 ½ minutes minimum or 2 seconds to connect the next step function regardless of change in demand. |
| | 4) | Shuts down all connected loads when a power loss of 20 milliseconds occurs and re-sequences step function with time delay to re-establish proper % of load for signal error within span. |

Option function – integration (PI) of input signal to provide control around setpoint. (Always controls to setpoint without signal error or span).

Modulating Method

When a portion of the 904 controller's load is required to modulate, a PWM (Pulse Width Modulated) signal is available to proportionally modulate the SCR section of the load from 0 to 100%. The PWM signal is capable of driving six (6) SCR Solid State Relays (6 single phase or 3 three phase) circuits integrally together with up to 14 sequenced stages. When the SCR load is larger than the sequenced stage(s), a Modulating Adjustment is available for matching the SCR % to the Sequenced Stage(s) %. When modulation is not required together with sequencing stages, a 745 Series controller is applicable.

Fault Protection

The controller continuously monitors electrical line disturbances to provide "Fault Protection" against "Relay Chatter" and "Brown Out". These features assure that power abnormalities do not adversely affect the operation of the controller. When a fault does occur, the controller instantly "shuts down" (disconnects all loads). A re-start of all stages in sequence at the selected time delay programmed, occurs once a steady state of power is established.

Time Delay

A unique feature of the time delay between stages is provided by averaging the temperature over the time delay rather than energizing the stage at the end of the time delay. This feature provides smooth controlled transitioning between stages of the average temperature rather than temperature at the end of the delay. Time Delay before stages energize, is adjustable from 2 seconds to 5 minutes; turn off delay is fixed at 2 seconds.

Internal Ramp Staging

A special exclusive feature of the Imbedded Software automatically divides the incremental stages used, plus the modulating stage (circuit), into the controllers internal ramp. It subsequently overlays the stages over the V DC, mA, or 135 ohm span to set the specific "turn on" points in relation to the controller internal ramp. The program additionally selects the differential (hysteresis) automatically at 1/3 of the value between the stages. Based on the stages selected, this feature optimizes the differential to minimize premature rapidly energizing and dis-energizing of stages.

Outputs

Each Relay output is isolated and rated for resistive and inductive loads. Individual terminals are provided on both sides of the SPNO output; this allows the installer to common the loads as necessary to meet requirement of Class II or Class I transformer limitations. The Sequencer is available with 4 or 6 stages standard. Additional "Plug In" stages are available in 2 or 4 stage modules providing up to a maximum of 14 stages. (See 14 Stage Sequencer picture.)

Two additional signal outputs are provided: a Pulse Width Modulated or variable 0-10 V DC analog signal is provided to drive SCR's or other proportional controls as may be required



904-S14VmA

Optional/Accessories

All of the aforementioned features are standard within the 904 or 745 Sequencer/Step controller. All other features are optional, and can individually or collectively be incorporated in the System as required. These enhancement/features included:

PI Integration- The integration of the Proportional Input Signal in Firmware, over time, for providing the control of a load, at set point without signal error (offset).

On Board Set Point - A “Plug In”, On Board Set Point with Remote Sensor Module, to the 904-S or 745-S, in two Temperature Ranges; 50-90F and 30-180F. Dedicated Direct or Reverse Acting Modes are available.

Plug In Relay Boards - Plug In Relay boards in 2 and 4 Stages for adding additional stages to the 904-S Sequencer or 745-S Step Controller.

Thermostats - 906 Series wall mounted Thermostats are available for providing all necessary input signals for all controllers in this control system.

NOTE:See Product Data for details for each of the above Accessories/Enhancements in this document.

Layout & Nomenclature

The Input/Output connections and Nomenclature of marking that identify the actual location of functions are noted in the full size depiction below. In addition, adjustments for Modulation %, Time Delay and Integration are identified and described. An instruction for Programming the DIP switches and description of the individual Functions is outlined for the nine designated ON or Off positions. The On Board Set point OBS plug in Card is outlined by the four PCB plug-in connectors which are at the corners of the plug-in assembly. When the controller requires 135 ohm input, a 745/904-135 Accessory also utilizes the plug-in connectors

PCB INPUT/OUTPUT TERMINAL NOMENCLATURE

GND	GROUND – ALL GROUNDS ARE COMMON
DIS	DISABLE – DISABLES PCB WHEN CLOSED TO GROUND
OUT	OUTPUT – MODULATED PULSE WIDTH OR 0–10 VDC OUTPUT
24V	24VAC POWER SUPPLY INPUT FOR PCB LOGIC
COM/NO	SPNO DRY CONTACTS FOR ISOLATED 24VAC CIRCUITS
2–10 4–20	DC VOLTS MILLIAMPS INPUT

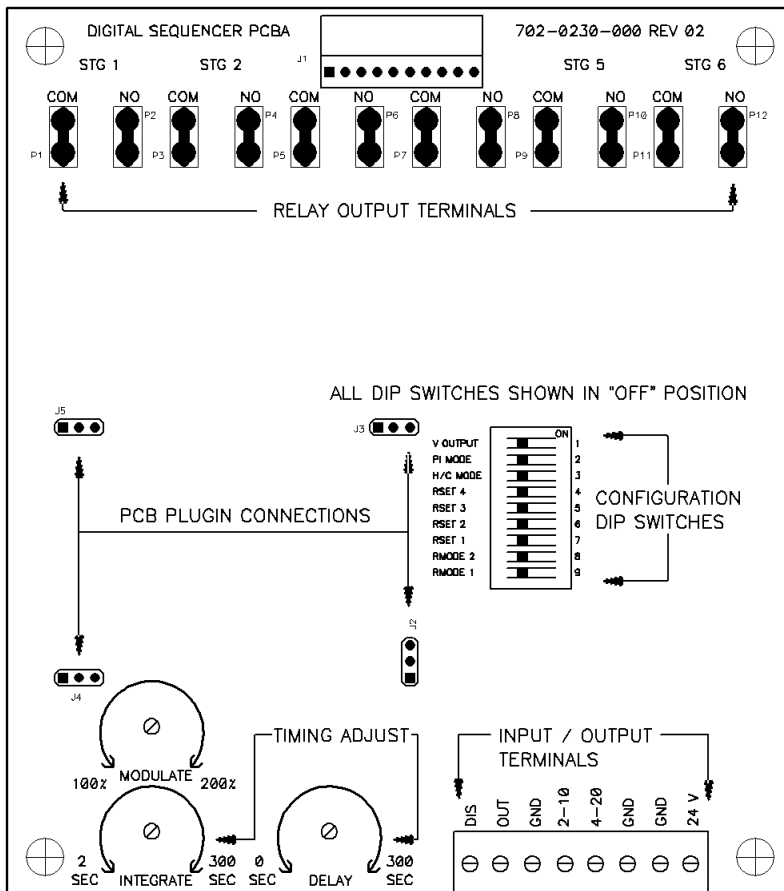

PCB TIMING ADJUSTMENTS

MODULATE	% OF ADJUSTMENT TO MODULATION STAGE
DELAY	TIME OF DELAY BETWEEN STAGE ACTIVATIONS
INTEGRATE	TIME OF INTEGRATION OF INPUT SIGNAL

DIP SWITCH POSITION / FUNCTION

DESIGNATOR	STATE	FUNCTION
1. V OUTPUT	OFF	PROVIDES 0-10VDC RAMP ON OUTPUT PIN
1. V OUTPUT	ON	PROVIDE 10V PWM SIGNAL ON OUTPUT PIN
2. PI MODE	OFF	DOES NOT PERFORM PI FUNCTION
2. PI MODE	ON	PERFORMS PI FUNCTION WHEN INSTALLED
3. H/C MODE	OFF / ON	NOT USED

SWITCH 4 THRU 7 ENCODES # OF RELAYS IN USE

STAGES	0	1	2	3	4*	5	6*	7	8	9	10	11	12	13	14
4. RSET 4	OFF	OFF	OFF	OFF	OFF	OFF	OFF	OFF	ON	ON	ON	ON	ON	ON	ON
5. RSET 3	OFF	OFF	OFF	OFF	ON	ON	ON	ON	OFF	OFF	OFF	OFF	ON	ON	ON
6. RSET 2	OFF	OFF	ON	ON	OFF	OFF	ON	ON	OFF	OFF	ON	ON	OFF	OFF	ON
7. RSET 1	OFF	ON	OFF	ON	OFF	ON	OFF	ON	OFF	ON	OFF	ON	OFF	ON	OFF

SWITCH 8 & 9 SELECT RELAY ACTIVATION MODE

	LIFO	FIFO	BINARY A (4 RELAYS MAX)	BINARY B (3 RELAYS MAX)
8. RMODE 2	OFF	ON	OFF	ON
9. RMODE 1	OFF	OFF	ON	ON

NOTE: 745 & 904 CONTROLLER SWITCHES ARE FACTORY SET TO 4 OR 6 STAGES AS MANUFACTURED.

IMPORTANT: WHEN ADDITIONAL STAGES ARE USED, OEM MUST PRESET (RE-SET) DIP SWITCHES TO QUANTITY OF STAGES IN USE.

SPECIFICATIONS

Sequencing/Step Controllers

Models 904 Series

904-S4 & 904-S6, with Pulse Width Output

Models 745 Series

745-S4 & 745-S6, without Pulse Width Output

General

Type Controller
Function

Microprocessor Based
Direct or Reverse Acting

Power

Volts

20-30VAC Source

Amps

Total Stages	4	6	8	10	12	14
	.39	.45	.51	.56	.61	.65
	12.0	13.8	15.5	17.1	18.5	19.3
	Std.	Std.	<-----Optional----->			

VA

Logic

Inputs

Volts (Typically 0-10V)

2-10V DC

Milli-Amps

4-20 mA

Ohms (optional)

0-135 ohms

Controller Disable N.O.

Disable Terminal to Ground

Output/Ratings

V DC Pulse Width Modulated for 904 Series only	Max. 6 SCRs
Analog	0-10V DC
Relays Isolated, Normally Open, SPST	
Resistive, 120v max	5 Amps
Inductive, 120v max Pilot Duty	1/8 HP & 90 VA
Maximum SCR Switches @ 24V AC	6
Ambient, Min/Max	32°F/0°C & 160°F/75°C
Humidity	Non-condensing

Time Delay of Stages

ON-Adjustable, Averaging	2-300 sec.
OFF-Fixed, non adjustable	2 sec.

Control Methods

Proportional-Output Increases Proportional to Input	Std.
Integral- Output averaged to input over time delay selected	Std.
Staging Mode-LIFO, FIFO, Binary A, Binary B	Std.
Integration (PI) Output Integrated over Time	Optional
Main PCB 904-S	5.5"Lx4.9"Wx1.2"H

Features

Controller Mode	Direct Acting (cooling) or Reverse (heating)
Modulating Stage adjustable	100% to 200%
Fault Protection	Brown Out/Relay Chatter
PI (Integration)	Optional
Pulse (output) Indicator on Logic & SCR	LED
Relay Indicator each stage	LED

Accessories (Optional)

PI Integration, Firmware	Selectable
On Board Set Point with Remote Sensor	Plug In
Thermostats 906-VmA	V DC/mA Output
906-P use with 905-S (Slaves only)	Pulse Width Output
Plug In Relay Boards 904-2E or 745-2E	2 stages
904-4E or 745-4E	4 stages
Dimensions 904-2 or 4E	2"Lx4.9"Wx1.9"H

Wiring Diagrams for Line Voltage & Low Voltage Connections

In the following pages, Wiring Diagrams and information are provided for connecting components and accessories. These Diagrams may provide multiple input or output options as well as the inclusion of accessories. You will note the number of components that can be served by the various outputs, as well as the amplitude of the output control signal.

The connection for protecting the SCRs with the 905-TCO, when used, is shown located on the first SCR in the group; therefore it protects all subsequent SCRs. If each individual SCR is required to be individually protected in the group, an additional 905-TCO must be located and connected to interrupt each SCR on each Heat Sink.

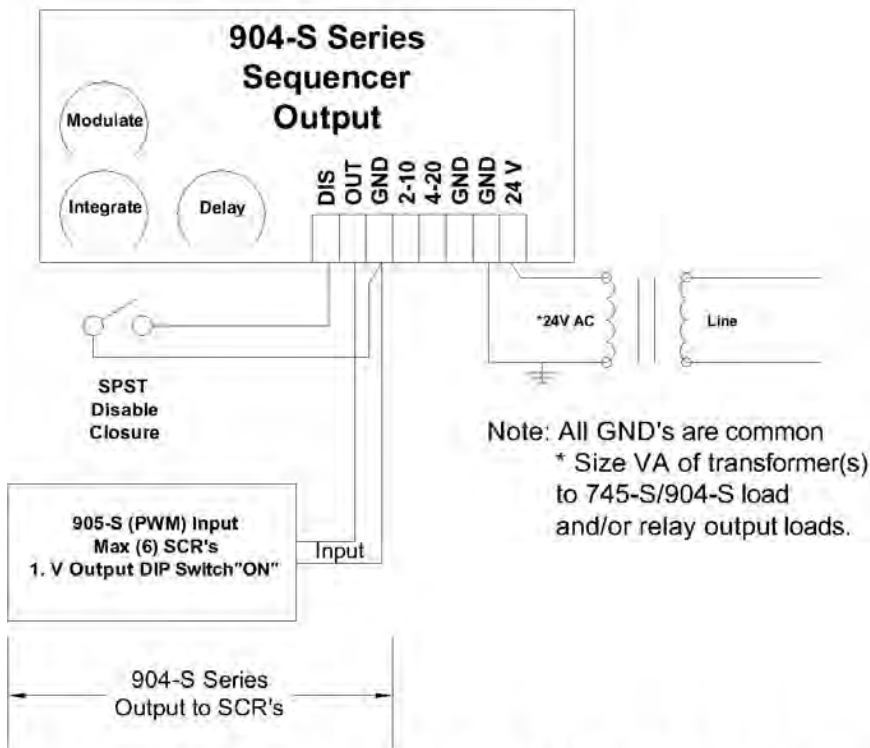

PWM Output Section 745-S or 904-S Series Step/Sequencer Controller

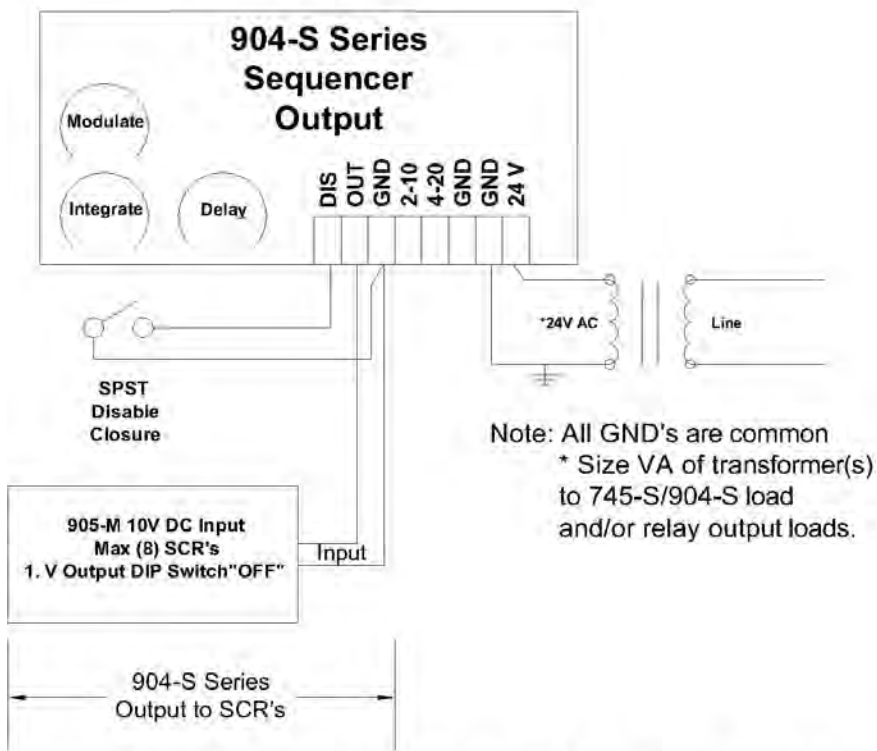

10V DC Output Section 745-S or 904-S Series Step/Sequencer Controller

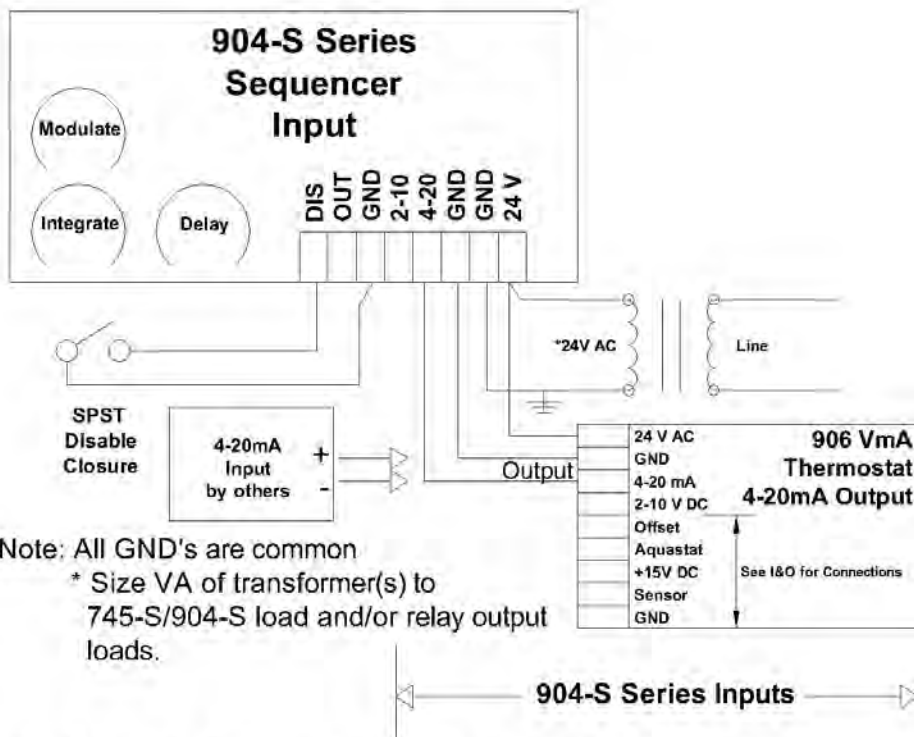

4-20mA Input Section 745-S or 904-S Series Step/Sequencer Controller

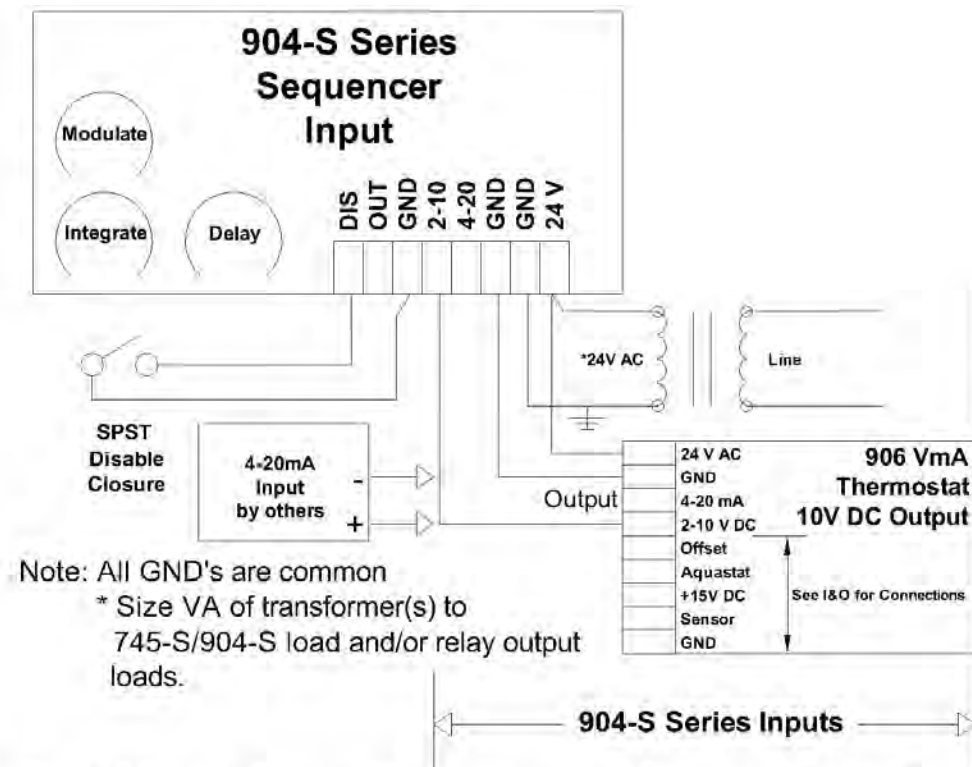

0-10V DC Input Section 745-S or 904-S Series Step/Sequencer Controller

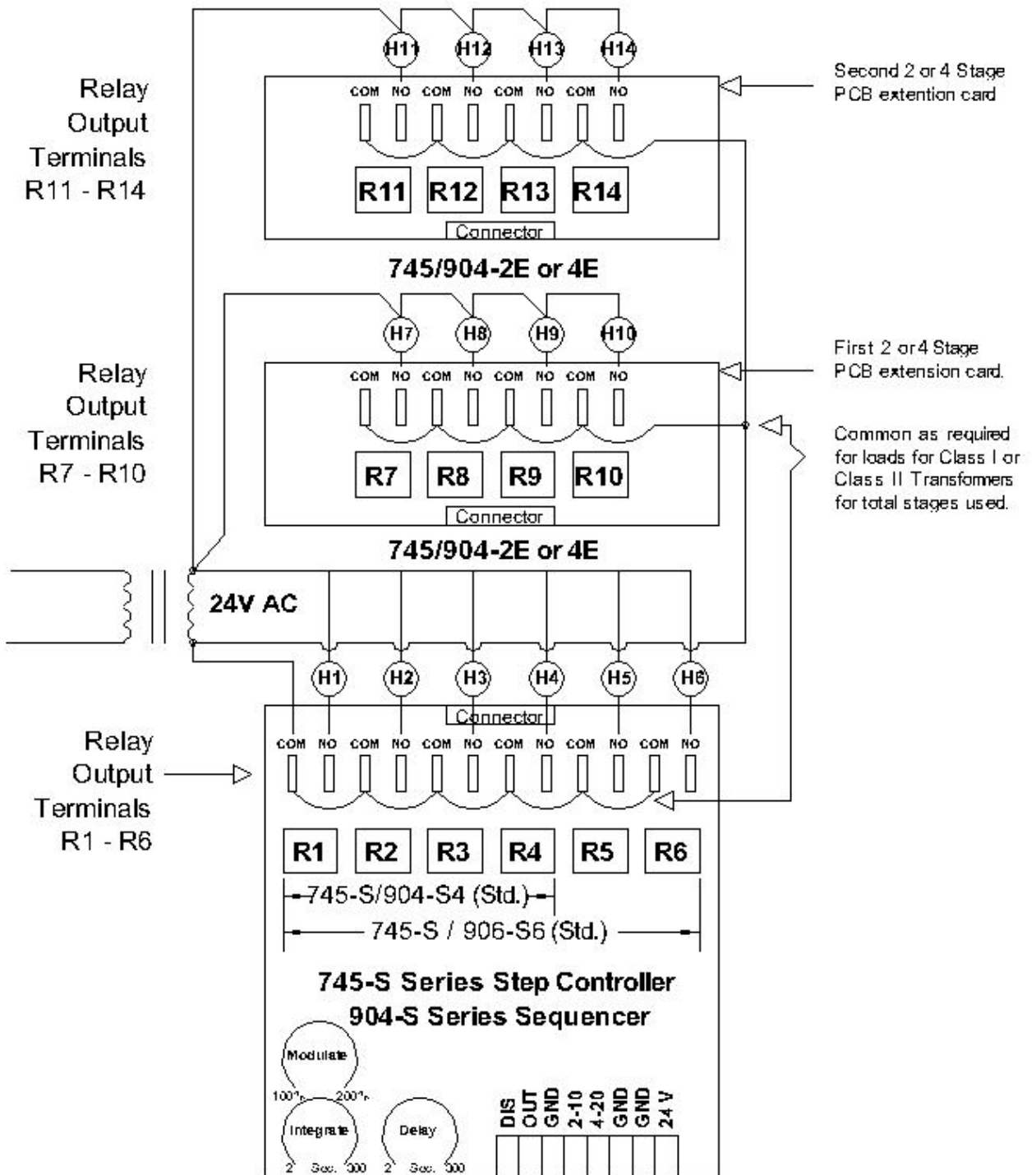

Typical (14) Relay Output connection (6) installed on 745-S or 904-S, (8) installed on (2) 4E cards