

Hoffman Controls

Wiring Diagrams

812/814/816 -10D and -10E Series

Electronic Head Pressure Controls

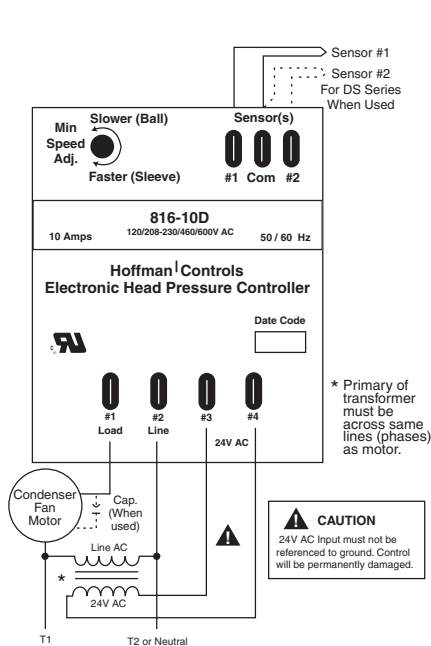

Figure 1 Wiring for 816-10D and 816-10DDS

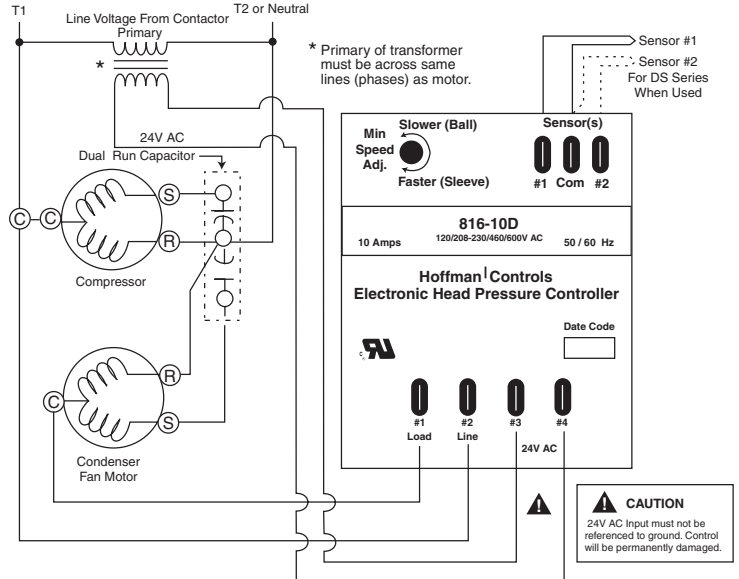

Figure 1b Dual Run Capacitor Wiring Diagram for the -10D Series

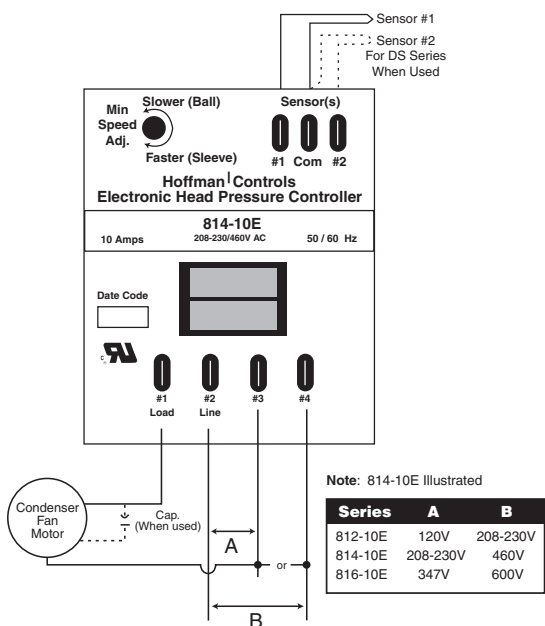

Figure 1a Wiring for 814-10E and 814-10EDS

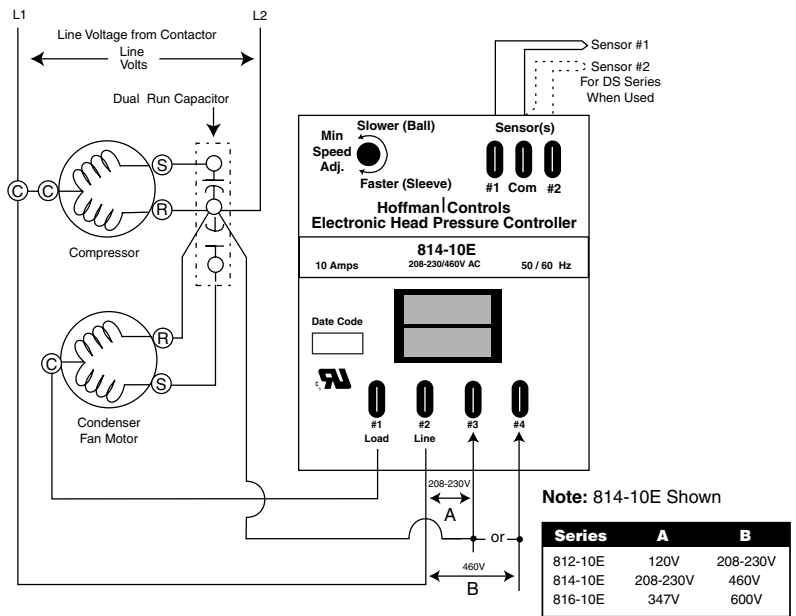

Figure 1c Dual Run Capacitor Wiring Diagram for the -10E Series

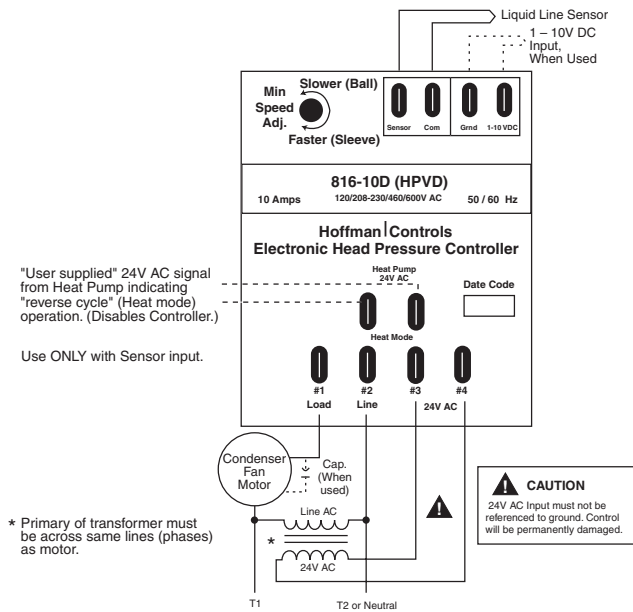

Figure 1d Wiring Diagram for the 816-10D (HPVD)

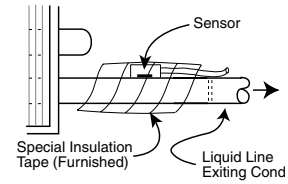

Figure 2 Sensor Mounting

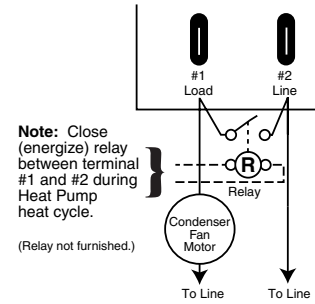

Figure 3 Wiring Modifications for Heat Pump Applications 812/814/816 -10D and -10E

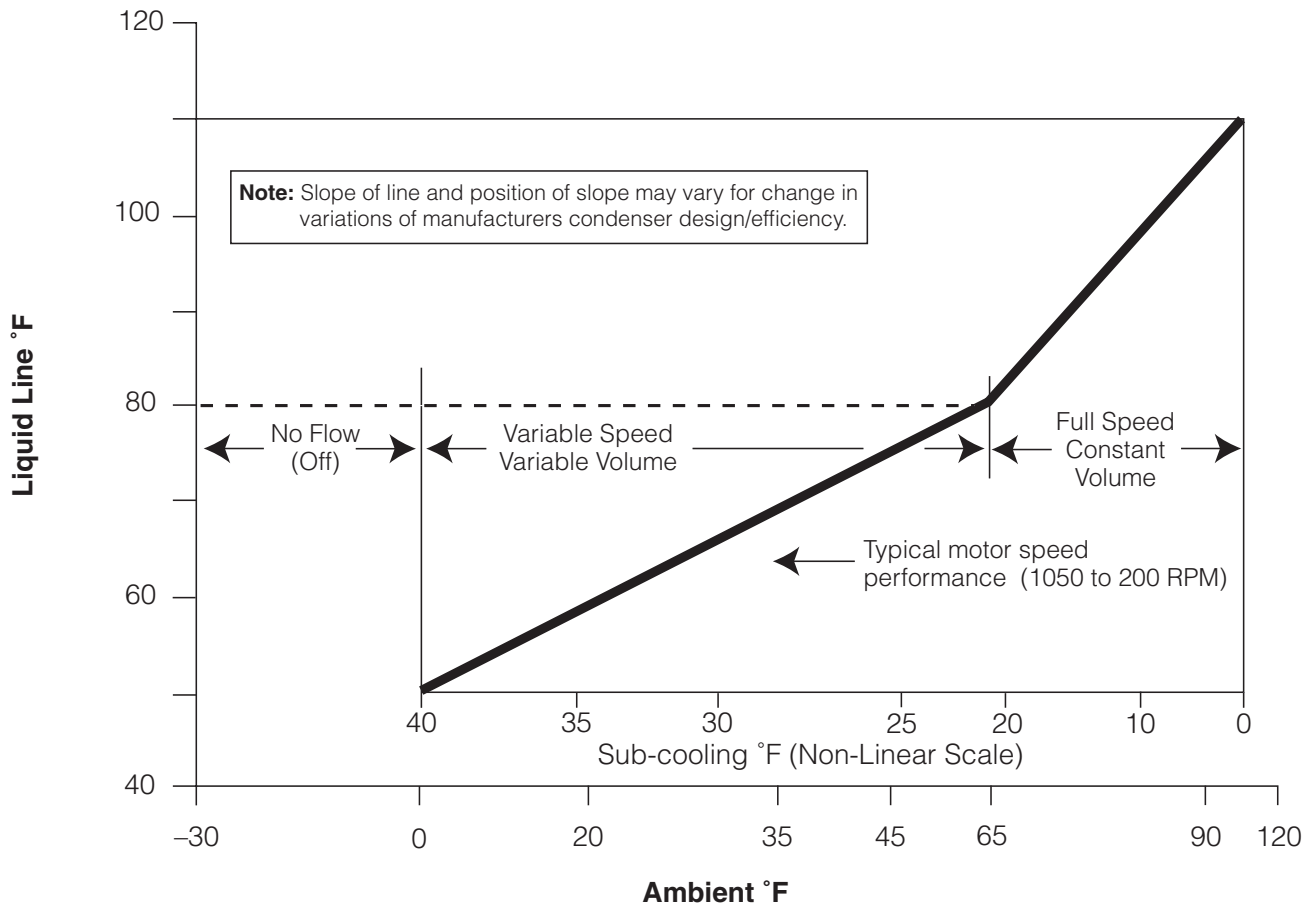

Figure 4 Liquid °F vs. Ambient °F and Sub-cooling °F

Hoffman|Controls